



Repair Part Sheet

BMS-151, BMS-152, BMS-154 Cylinder
 Form No. BMS151RP Rev. B Date: 20.5.2015



BELIUM Cylinders should be repaired only by a qualified operator or Authorized BELIUM Service Centers. Use Only BELIUM or other approved hydraulic oil. Release pressure in hydraulic system and disconnect hose(s) before making repair.

Parts List

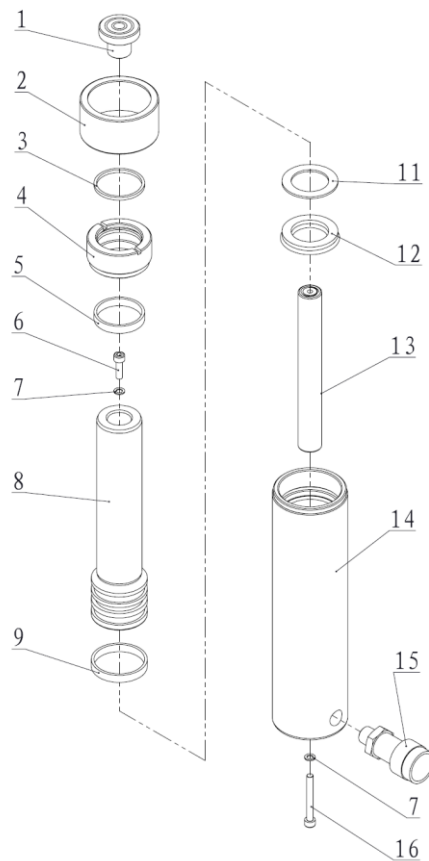

Item No.4: Torque to 22-44 ft. lbs.
 [30-60 Nm].

Item No.16: Torque to 22-44 ft. lbs.
 [30-60 Nm].

Item No.15: Torque to 22-44 ft. lbs.
 [30-60 Nm].

Apply Teflon tape or Loctite 545 thread sealant. Leave first complete thread free to prevent tape

Item No.	Part Number	Description	Qty.	Item No.	Part Number	Description	Qty.
1	SG-152G	Saddle	1	10★	21291	Gasket	1
2	BMS151-4	Thread	1	11★	24317	Y-ring	1
3★	21704	Wiper Ring	1	12	31014	Spring Assembly BMS-151 Only	1
4	BMS151-2	Stop Ring	1		31011	Spring Assembly BMS-152 Only	1
5	21623	Anti-wear Ring	1		31019	Spring Assembly BMS-154 Only	1
6	11004	Bolt	1	13	BMS151-1	Cylinder BMS-151 Only	1
7★	QY2-13	Copper Washer	2		BMS152-1	Cylinder BMS-152 Only	1
8	BMS151-3Y	Piston Rod BMS-151 Only	1		BMS154-1	Cylinder BMS-154 Only	1
	BMS152-3Y	Piston Rod BMS-152 Only	1	14	BAC-201A	Coupler	1
	BMS154-3Y	Piston Rod BMS-154 Only	1	15	11006	Bolt	1
9	21630	Anti-wear Ring	1				

★ Items included in Repair Kit, Repair Kit order number: **BMS151-RP-B**